

# REPLAY *next*

**STOSA**  
CUCINE

UN PATRIMONIO DI MEMORIA  
E FUTURO

**Qualità, tradizione e forza nel prezzo:** sono questi gli ingredienti, che sapientemente dosati, hanno permesso a Stosa Cucine di mettere a punto la "ricetta giusta" per ottenere un prodotto eccellente e conquistare un'importante primato nel mercato.

**Qualità,** non significa solo bontà del prodotto, per Stosa Cucine è anche il risultato di un'approfondita ricerca nel design, nella tecnologica e nell'ampliamento della gamma dei modelli, sostenuta da costanti investimenti produttivi. Per un miglioramento continuo.

**Forza nel prezzo:** ovvero costruire cucine garantendo il miglior rapporto qualità/prezzo. Ad un prodotto pregiato corrisponde una spesa accessibile.

**Tradizione:** da oltre quarant'anni dietro ad ogni modello Stosa Cucine vi sono tutta la passione e la genuinità di una famiglia, quella del presidente Maurizio Sani che, assieme ai figli David, Mauro e Leonardo, guida con successo l'azienda verso promettenti orizzonti.

A HERITAGE OF MEMORY  
AND FUTURE

**Quality, tradition and strength in the price:** these are the ingredients which, carefully dosed, have enabled Stosa Cucine to prepare the "right recipe" for obtaining and excellent product and achieving an important lead in the market.

**Quality** doesn't only mean goodness of the product. For Stosa Cucine it is also the result of in-depth research in the design, technology and in widening the range of models, backed by ongoing productive investments. For ongoing improvement.

**Strength in the price:** i.e. making kitchens and guaranteeing the best value for money.

A quality product at an affordable price.

**Tradition:** for over 40 years, behind every Stosa Cucine model there has always been all the passion and genuineness of a family, and namely that of chairman Maurizio Sani who, together with his children David, Mauro and Leonardo, successfully leads the company towards promising horizons.



Maurizio Sani  
Presidente di Stosa Cucine

# REPLAY<sub>next</sub>

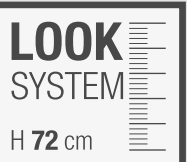

# REPLAY<sup>next</sup>

CON LOOK SYSTEM,  
SI APRE UN MONDO  
DI POSSIBILITÀ

WITH LOOK SYSTEM, OPENS UP A WORLD OF POSSIBILITIES



## 01 SISTEMA CON MANIGLIA

SYSTEM  
WITH HANDLE

## 02 SISTEMA "GOLA" ALLEGRA

ALLEGRA "GROOVE"  
SYSTEM

## 03 SISTEMA MANIGLIA A "TASCA" GLORIA

GLORIA "POCKET"  
HANDLE SYSTEM

## 01 PAG. 6

### REPLAY + MANIGLIA HANDLE

Oltre al sistema gola ALLEGRA, al modello REPLAY sono abbinare delle maniglie che possono essere di serie, consigliate o opzionali.

In addition to the system ALLEGRA throat, REPLAY are matched to the model of handles that can be standard, recommended or optional.

Di serie  
Standard  
Pag. 86



Duse A

Duse B

Opzionale consigliata  
Optional recommended  
Pag. 86



Onda

Opzionali (vedi tutte a pagina 87)  
Optional (See all on page 87)



Fiocco

Line

Valzer

Twist

MDO



## 02 PAG. 32

### REPLAY + ALLEGRA SISTEMA "GOLA" - "GROOVE" SYSTEM

ALLEGRA è un sistema gola che permette di ospitare le varie tipologie di finiture del sistema LOOK SYSTEM escludendo le ante in finitura vetro di BRILLANT. Le varie finiture possono essere integrate con la vasta gamma dei colori laccati COLORS.

ALLEGRA is a groove system that can receive the various types of finishes of the LOOK SYSTEM, excluding the BRILLANT glass finish doors. The various finishes can be integrated with the wide range of COLORS lacquers.

Finiture gola Groove finish

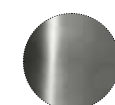

Brill



Bianco opaco  
Matt white



Piombo opaco  
Matt lead

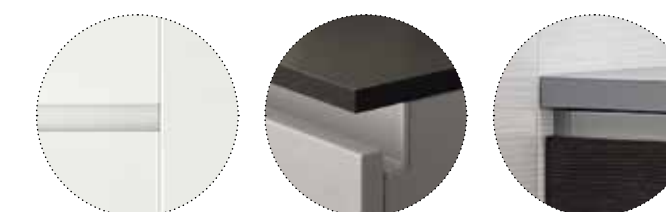

## 03 PAG. 68

### REPLAY + GLORIA SISTEMA MANIGLIA A "TASCA" - "POCKET" HANDLE SYSTEM

GLORIA è un sistema con maniglia a "tasca" incassata in testa all'anta con gola. La maniglia Up è incassata in testa all'anta e la gola facilita l'apertura.

Gloria is a system with handle "pocket" embedded in the head with the leaf throat. Up The handle is recessed in the head and throat sash for easy opening.

Finiture gola e maniglia Up Groove and Up handle finishes

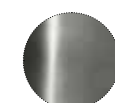

Brill



Bianco opaco  
Matt white



Brown



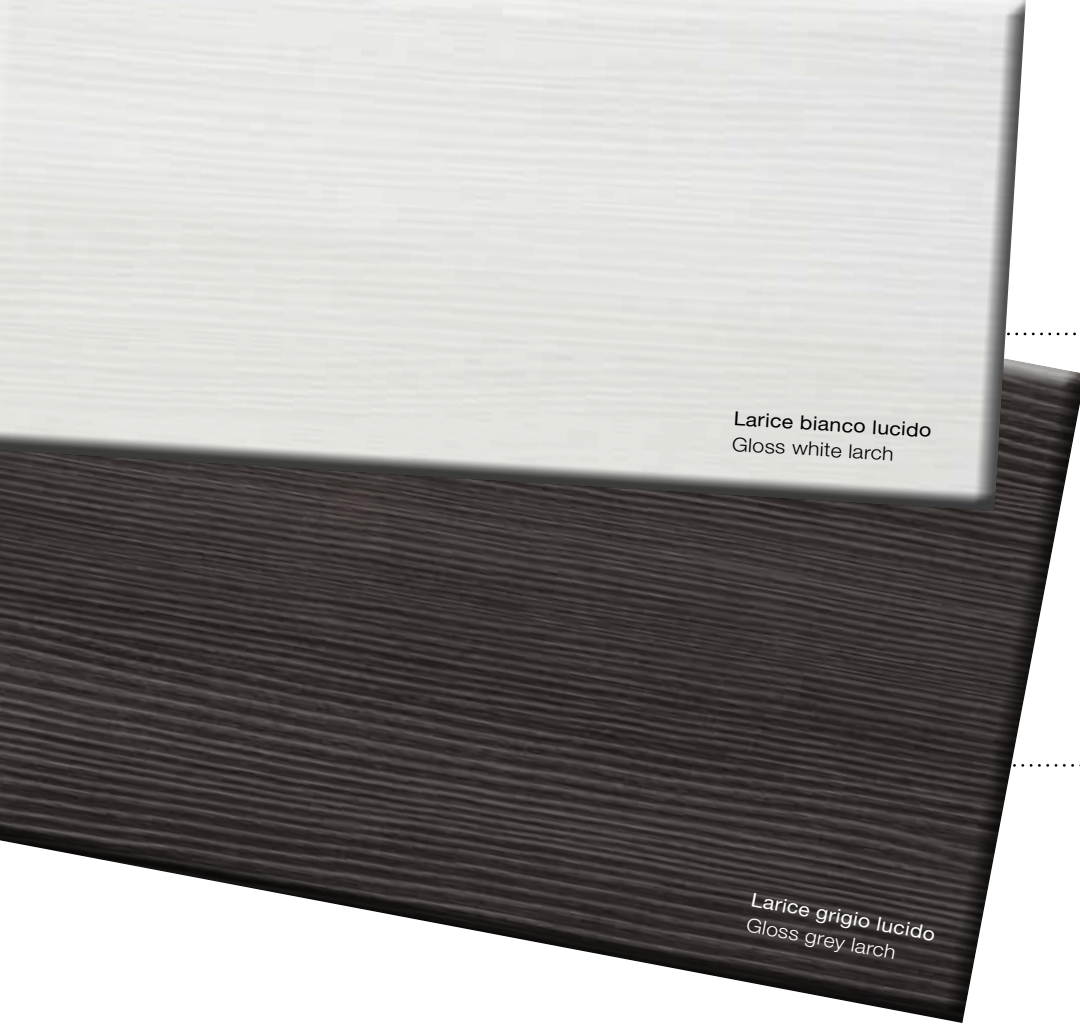

**POLIMERICI LUDICI**  
**FINITURA LARICE**  
**GLOSS POLYMERIC**  
**LARCH FINISH**

**REPLAY***next*

Spessore anta **23 mm.**  
 Door thickness 23 mm.

**POLIMERICI LISCI STANDARD**  
**STANDARD SMOOTH POLYMERIC**



**POLIMERICI DOGATI STANDARD**  
**STANDARD SLATE POLYMERIC**

**LUCIDO**  
**GLOSS**

**OPACO**  
**MATT**



**A RICHIESTA**  
**POLIMERICI LUCIDI**  
**GLOSS POLYMERIC**



**A RICHIESTA**  
**POLIMERICI OPACHI**  
**MATT POLYMERIC**



**A RICHIESTA**  
**POLIMERICI VENATI MATERICI**  
**GRAINED TEXTURED POLYMER**



# REPLAY + MANIGLIA HANDLE

Oltre al sistema gola ALLEGRA, al modello REPLAY sono abbinata delle maniglie che possono essere di serie, consigliate o opzionali.

In addition to the system ALLEGRA throat, REPLAY are matched to the model of handles that can be standard, recommended or optional.







## Composizione 01

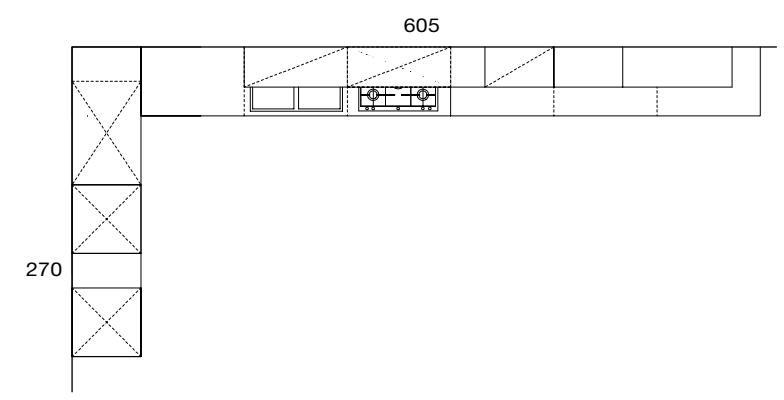

**Composizione 01**  
**REPLAY MANIGLIA HANDLE.** Cucina con maniglia Onda opzionale. Basi con ante e cassetti in finitura onix opaco a richiesta, colonne in finitura pino nero venato a richiesta. Pensili con ante in finitura pino nero venato e grigio daitona opaco a richiesta. Vani a giorno Tetris in laccato opaco bianco. / Kitchen with Wave handle (optional). Base units with doors and drawers in matt onyx just in time finish. Tall units in black grained pine just in time finish. Wall units with doors in black grained pine finish and matt daitona grey just in time finish. Tetris open compartments in varnished matt white.

Replay	polimerico venato grained polymeric	Replay	polimerico opaco matt polymeric	Tetris	laccato opaco matt lacquered
	Pino nero Black pine A RICHIESTA		Onyx A RICHIESTA		Grigio daitona Daitona grey A RICHIESTA
			Bianco White		

# EFFETTO CHIAROSCURO

CHIAROSCURO EFFECT



## ESTETICA FUNZIONALE

LE CAPIENTI COLONNE IN  
FINITURA PINO NERO VENGONO  
ALLEGGERITE GRAZIE  
ALL'INSERTO VERTICALE  
LACCATO BIANCO OPACO:  
GLI ELEMENTI A GIORNO  
DIVENTANO COSÌ NON SOLO  
UTILI PORTA OGGETTI MA  
SEGNO GRAFICO DOMINANTE.



## PRACTICAL AESTHETICS

The spacious tall units with a black pine finish are given a lighter feel by the vertical varnished matt white insert: the open compartments are no longer just a handy place for displaying objects, but prevailing graphic sign.



# SENSAZIONE NATURALE

NATURAL SENSATION



**Composizione 02**  
**REPLAY MANIGLIA HANDLE.** Cucina con maniglia Bridge opzionale. Basi con ante in finitura pino basalto venato a richiesta. Pensili e colonne con ante in finitura onyx opaco a richiesta. Vani a giorno Tetris in laccato opaco grigio Piacenza. / Kitchen with Bridge handle (optional). Base units with doors in grained basalt pine Just in time finish. Wall units and tall units with doors in matt onyx Just in time finish. Tetris open compartments in varnished matt Piacenza grey.

Replay	polimerico venato grained polymeric	Replay	polimerico opaco matt polymeric	Tetris	laccato opaco matt lacquered
					
Pino basalto Basalt pine A RICHIESTA		Onyx A RICHIESTA		Grigio Piacenza Piacenza grey	

Composizione 02 

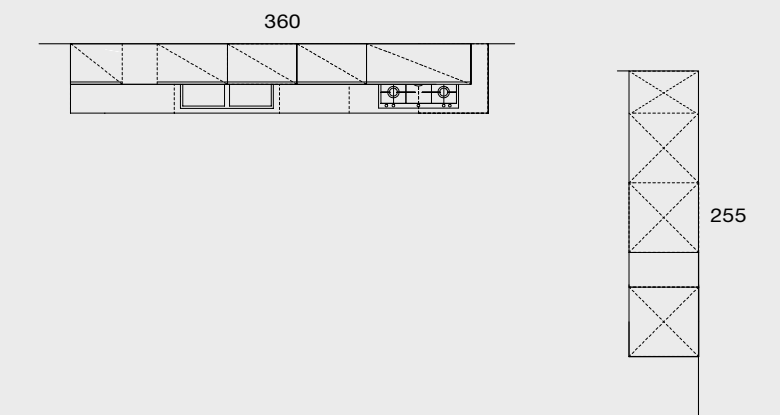

# UN MATRIMONIO PERFETTO

A PERFECT WEDDING

## Composizione 03

**REPLAY MANIGLIA HANDLE.** Cucina con maniglia Onda opzionale. Basi e colonne con ante in finitura bianco lucido, pensili con ante in finitura pino grigio venato a richiesta. Vani a giorno Tetris in laccato opaco acquamarina. / Kitchen with Wave handle (optional). Base units and tall units with doors in glossy white finish. wall units with doors in grained grey pine Just in time finish. Tetris open compartments in varnished matt aquamarine.

Replay polimerico liscio smooth polymeric	Replay polimerico venato grained polymeric	Tetris laccato opaco matt lacquered
		
Bianco opaco Matt white STANDARD	Pino grigio Grey pine A RICHIESTA	Acquamarina Aquamarine

## Composizione 03

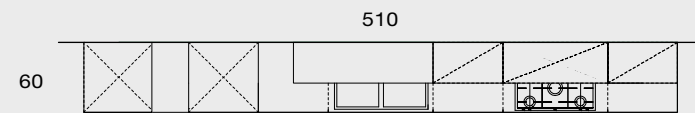



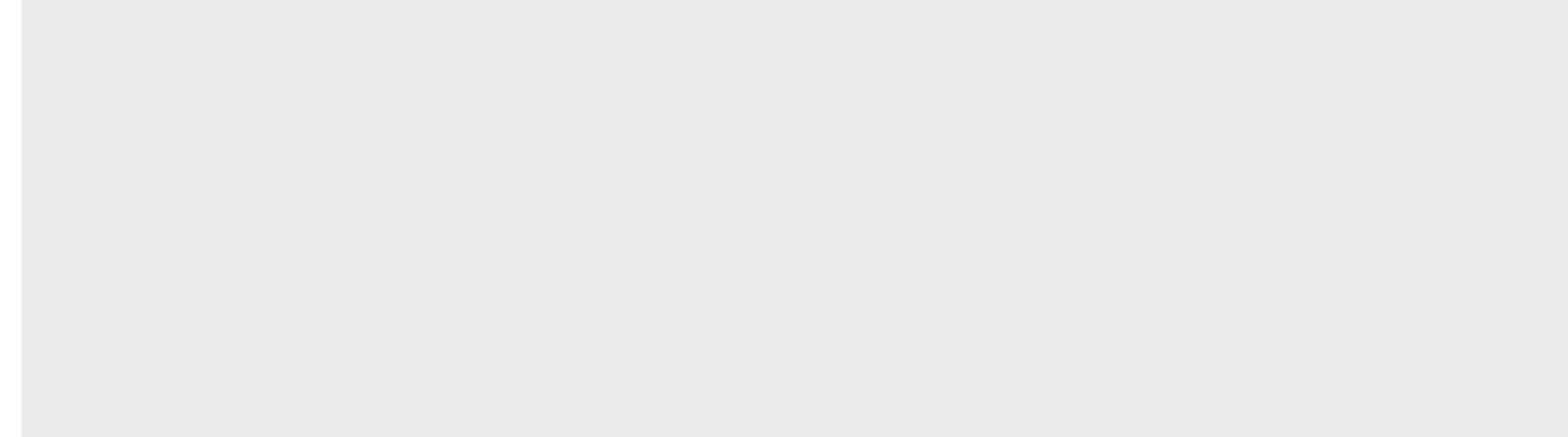

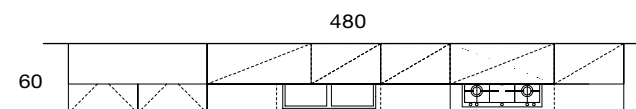

## Composizione 04



**Composizione 04**  
**REPLAY MANIGLIA HANDLE.** Cucina con maniglia *Onda* opzionale. Basi e colonna con ante in polimerico pino sabbia venato, pensili in polimerico bianco opaco. Vani a giorno *Tetris* laccato bianco gesso opaco. / Kitchen with *Wave* handle (optional). Base units and tall unit with doors in grained sand pine polymeric. Wall units in matt white polymeric. *Tetris* open compartments in varnished matt chalk white.

<p>Replay polimerico liscio smooth polymeric</p>  <p>Bianco opaco Matt white STANDARD</p>	<p>Replay polimerico venato grained polymeric</p>  <p>Pino sabbia Sand pine A RICHIESTA</p>	<p>Tetris laccato opaco matt lacquered</p>  <p>Bianco gesso Chalk white</p>
--	--	--



VOLUMI  
SOSPESI  
PENSILI E BASI DALLA  
FORMA INSOLITA  
PERMETTONO DI CREARE  
SOLUZIONI CAPIENTI  
E ALLO STESSO TEMPO  
VISIVAMENTE MOLTO  
LEGGERE ED ELEGANTI.

WALL-MOUNTED  
VOLUMES  
unusually shaped wall and  
base units create solutions  
that are spacious yet  
visually elegant and  
unimposing.

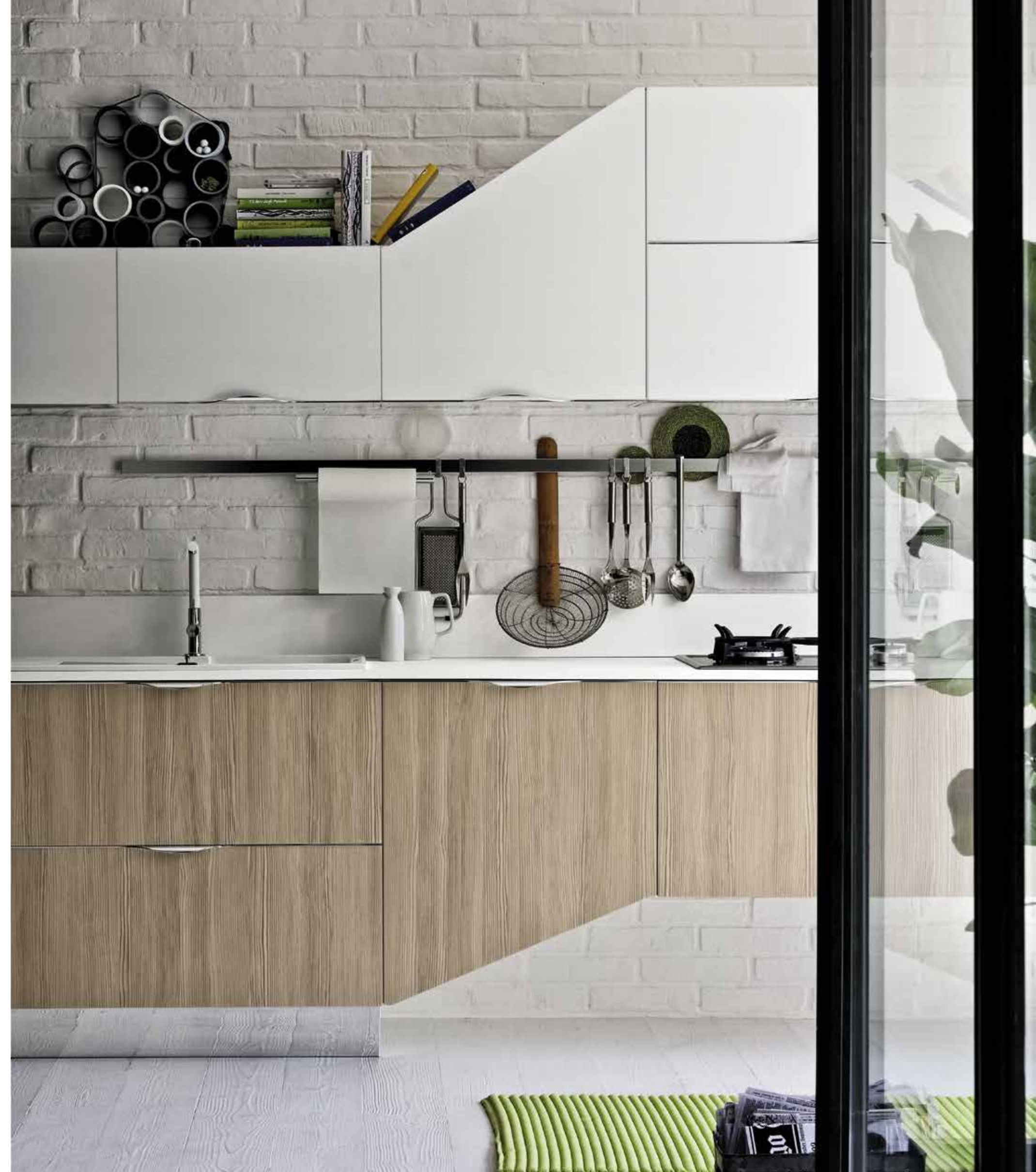



# L'ESSENZA DEL DESIGN

THE ESSENCE OF DESIGN



**Composizione 05**  
**REPLAY MANIGLIA HANDLE.** Cucina con maniglia Line opzionale. Composizione con basi in larice bianco lucido e colonne in larice grigio lucido. Il piano di lavoro avanzato presenta la forma ergonomica Penta. Le basi ribassate della zona living sono in larice grigio lucido. Pensili in larice grigio lucido e vetro stopsol. / Kitchen with Line optional handle. Composition with base units in gloss white larch and column units in gloss grey larch. The forward work top features the ergonomic Penta shape. The low base units of the living area are in gloss grey larch, whereas the wall units are in gloss grey larch and stopsol glass.

Replay polimerico lucido gloss polymeric	Brillant vetro colorato coloured glass
	
Larice bianco White larch STANDARD	Larice grigio Grey larch STANDARD
	
	Stopsol STANDARD

Composizione 05 

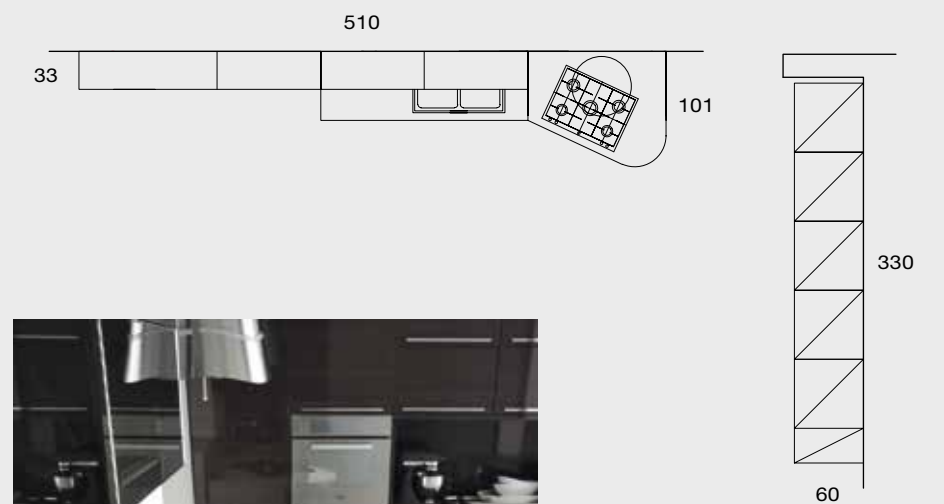





# BIANCO TOTALE

TOTAL WHITE



**Composizione 06**  
**REPLAY MANIGLIA HANDLE.** Cucina con maniglia Valzer opzionale in finitura cromo lucido. Basi e pensili in finitura bianco opaco. / Kitchen with optional Valzer handle gloss chrome finish. Base units and wall units in matt white finish.

Replay polimerico liscio  
 smooth polymeric

Bianco opaco  
 Matt white  
 STANDARD

Composizione 06 

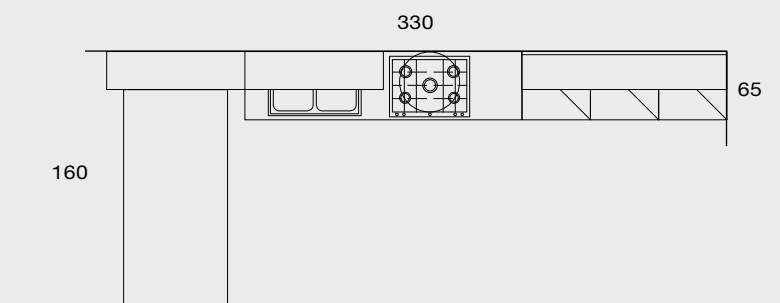



# SPAZIO AI PARTICOLARI

SPACE TO THE DETAILS



**Composizione 07**  
**REPLAY MANIGLIA HANDLE.** Cucina con maniglia opzionale MCO in finitura inox spazzolato. Basi e colonna in finitura rovere scuro dogato opaco, pensili in finitura crema dogato lucido completi di luce sottopensile. / Kitchen with MCO handle in brushed stainless steel finish. Base and column unit in matt dark oak slatted finish, wall units in gloss cream slatted finish complete with under-wall unit light.

Replay polimerico dogato  
 slatted polymeric

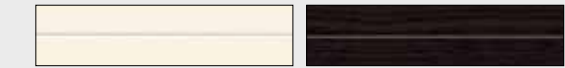

Crema lucido  
 Gloss cream  
 STANDARD

Rovere scuro opaco  
 Matt dark oak  
 STANDARD

Composizione 07

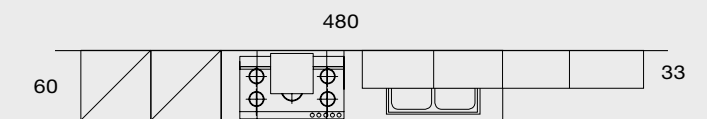





## Composizione 08

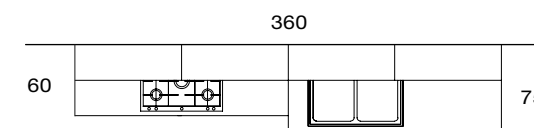

### Composizione 08

**REPLAY MANIGLIA HANDLE.** Cucina con maniglia Line opzionale in finitura cromo. Ante in finitura noce opaco dogato e pensili in vetro corda (nelle colonne il vetro corda è dogato). Piano di lavoro inox spessore 15 cm. / Kitchen with optional handle Line in chrome finish. Doors in matt walnut slatted finish and wall units in cord-coloured glass (glass slatted for the columns). Stainless steel worktop (thick. 15 cm).

**Replay** polimerico dogato  
slatted polymeric



**Noce opaco**  
Matt walnut  
STANDARD

**Brillant** vetro colorato  
coloured glass



**Vetro corda liscio**  
Smooth cord glass  
OPTIONAL



**Vetro corda dogato**  
Slatted cord glass  
OPTIONAL

# CONTRASTO CROMATICO

CHROMATIC CONTRAST



**Composizione 09**  
**REPLAY MANIGLIA HANDLE.** Cucina con maniglia Line opzionale in finitura cromo. Ante in finitura noce opaco dogato e crema lucido. Pensili in vetro stopsol. / Kitchen with optional handle Line in chrome finish. Doors in matt walnut slatted and glossy cream finish. Wall units in stopsol glass.

<p>Replay polimerico dogato slatted polymeric</p>  <p>Noce opaco Matt walnut STANDARD</p>	<p>Replay polimerico liscio smooth polymeric</p>  <p>Crema lucido Gloss cream STANDARD</p>	<p>Brillant vetro colorato coloured glass</p>  <p>Stopsol STANDARD</p>
--	---	---

Composizione 09 

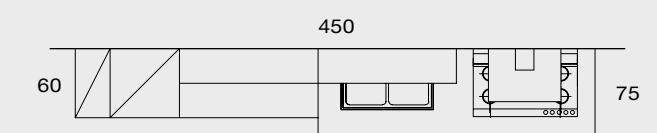



# TAVOLO A SCOMPARSA

FOLDAWAY TABLE

PRATICA ALTERNATIVA AL TRADIZIONALE TAVOLO, LA PENISOLA ALLUNGABILE SUPPORTATA DAL TELAIO "FRAME" FORMATA DA DOPPIO PIANO CON ALTEZZE SFALSATE DIVENTA ANCHE SPAZIOSA SUPERFICIE DI APPOGGIO E DI LAVORO.



A practical alternative to the traditional table, the extensible peninsula supported by the "Frame" consisting of a double top with staggered heights also becomes a spacious support and work surface.

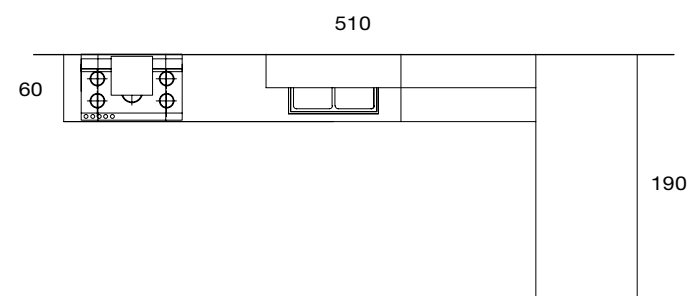

**Composizione 10**  
**REPLAY MANIGLIA HANDLE.** Cucina con maniglia Close opzionale in finitura cromo lucido. Basi con ante in finitura bordeaux lucido. Zona living: basi in vetro bianco e pensili in vetro satinato. / Kitchen with optional handle Close in gloss chrome finish. Base units in gloss bordeaux finish. Living area: base units in white glass and wall units in satin glass.

Composizione 10 

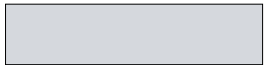

<b>Replay</b> polimerico polymeric	<b>Brillant</b> vetro colorato coloured glass	
		
<b>Bordeaux lucido</b> Gloss bordeaux A RICHIESTA	<b>Vetro satinato</b> Satin glass STANDARD	<b>Bianco lucido</b> Gloss white OPTIONAL





# REPLAY + ALLEGRA SISTEMA "GOLA" - "GROOVE" SYSTEM

Allegra è un sistema gola che permette di ospitare le varie tipologie di finiture del sistema Look System escludendo le ante in finitura vetro di Brillant. Le varie finiture possono essere integrate con la vasta gamma dei colori laccati Colors.

Allegra is a groove system that can receive the various types of finishes of the Look System, excluding the Brillant glass finish doors. The various finishes can be integrated with the wide range of Colors lacquers.

Finiture gola  
Groove finishes

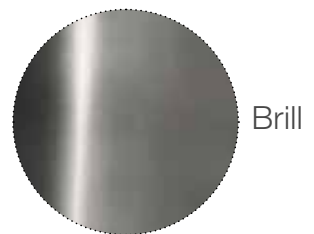

Brill

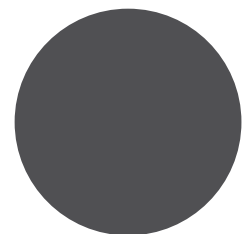

Piombo opaco  
Matt lead

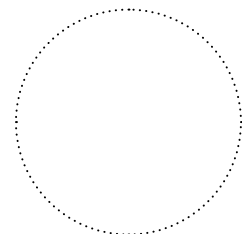





Bianco opaco  
Matt white







**Composizione 11**  
**REPLAY + ALLEGRA.** Cucina con gola in finitura bianco opaco. Basi con ante in finitura bianco opaco, inserto a giorno e piano in appoggio in finitura olmo mercurio. Pensili in finitura pino nero venato a richiesta e laccato arancio opaco, due vani a giorno in finitura olmo mercurio e uno laccato opaco piombo. Colonne in finitura pino nero venato a richiesta con inserto a giorno laccato arancio opaco. / Kitchen with groove in matt white finish. Base units with doors in matt white finish, open insert and top in mercury elm finish. Wall units in grained black pine Just in time finish and colors varnished matt orange. Two open compartments in mercury elm finish and one in colors varnished matt lead. Tall units in grained black pine Just in time finish, with colors open insert in varnished matt orange.

<b>Replay</b> polimerico polymeric	<b>Replay</b> polimerico venato grained polymeric	<b>Alevè</b> laminato laminated
		
<b>Bianco opaco</b> Matt white STANDARD	<b>Pino nero</b> Black pine A RICHIESTA	<b>Olmo mercurio</b> Mercury elm
<b>Tetris</b> laccato opaco matt lacquered		
<b>Arancio</b> Orange	<b>Piombo</b> Lead	

PIÙ SPAZIO  
 PER LE IDEE  
 UN STILE INCONFONDIBILE  
 CHE CONIUGA TRADIZIONE,  
 QUALITÀ ED INNOVAZIONE CON  
 FORME ELEGANTI E MATERIALI  
 INNOVATIVI TIPICAMENTE  
 MADE IN ITALY.

MORE ROOM FOR IDEAS  
 An unmistakable style that blends  
 tradition, quality and innovation  
 with elegant shapes and innovative  
 materials with a typical  
 Italian feel.

Composizione 11 

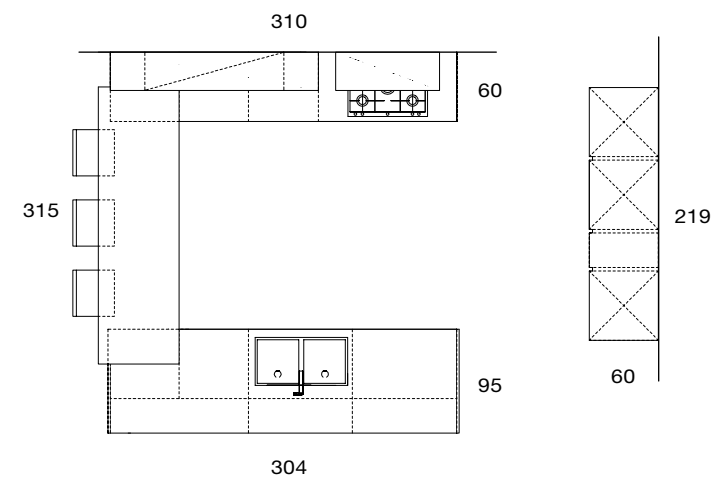



ARTE  
CONTEMPORANEA  
COME IN UN QUADRO MODERNO  
I COLORI GIOCANO UN RUOLO  
PRIMARIO NEL DEFINIRE GLI SPAZI  
ED I VOLUMI. I VANI A GIORNO  
VENGONO PROPOSTI IN FINITURA  
A CONTRASTO, SI TRASFORMANO  
COSÌ IN ELEMENTI JOLLY CHE  
SERVONO AD ESALTARE  
LE FORME DELLA CUCINA.



CONTEMPORARY ART  
Like in a modern painting, the colours  
play a leading role in defining spaces  
and volumes. The open compartments  
have contrasting finishes, transforming  
them into multi-purpose elements  
that highlight the shapes of the kitchen.

# SOLUZIONE VINCENTE

SUCCESSFUL SOLUTION



**Composizione 12**  
**REPLAY + ALLEGRA.** Cucina con gola in finitura bianco opaco. Basi e colonne in finitura bianco lucido. Pensili e mensole (top colonne compreso) in finitura pino grigio a richiesta. Top e schienale in finitura olmo bianco. /  
 Kitchen with groove in matt white finish. Base units and tall units in glossy white finish. Wall units and shelves (including tall unit top) in grey pine Just in time finish. Top and back panel in white elm finish.

Replay polimerico polymeric	Replay polimerico venato grained polymeric
	
Bianco lucido Gloss white STANDARD	Pino grigio Grey pine A RICHIESTA

Composizione 12 

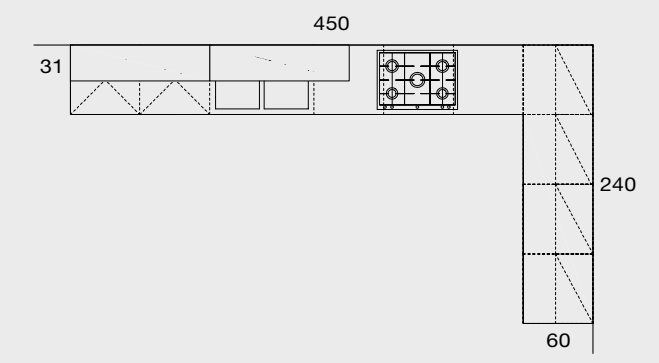



# LA TRADIZIONE SI EVOLVE

TRADITION EVOLVES



**Composizione 13**  
**REPLAY + ALLEGRA.** Cucina con gola in finitura brill. Basi sospese e vani a giorno in finitura larice grigio lucido. Pensili e colonne midi in finitura larice bianco lucido. / Kitchen with groove in brill finish. Gloss grey larch finish suspended base units and open compartments. Gloss white larch finish midi column units and wall units.

Replay polimerico lucido  
 gloss polymeric



Larice grigio  
 Grey larch  
 STANDARD

Larice bianco  
 White larch  
 STANDARD

Composizione 13 **LOOK SYSTEM**  
 H 72 cm

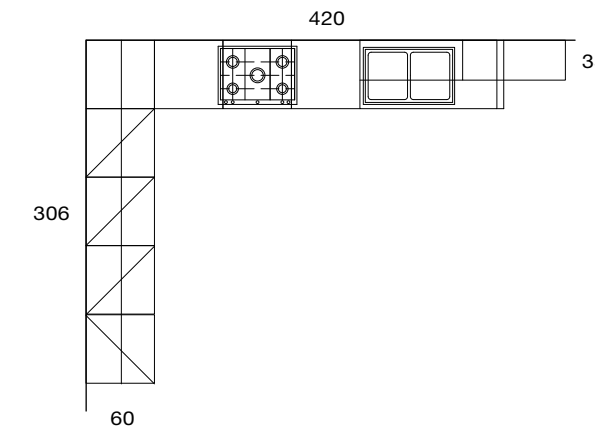

VERSIONE CON PENSILI BRILLANT IN VETRO STOPSOL  
 CON TELAIO ALLUMINIO BRILL.

Version with wall units in stopsol glass  
 and aluminium brill frame.

Brillant vetro colorato  
 coloured glass

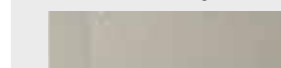

Stopsol  
 STANDARD

# UN GRANDE CLASSICO

GREAT CLASSIC



**Composizione 14**  
**REPLAY + ALLEGRA.** Cucina con gola in finitura brill. Basi in finitura ebano lucido a richiesta. Pensili e colonne in finitura crema lucido liscio. / Kitchen with groove in brill finish. Bases in gloss ebony finish Just in time. Wall and column units in gloss cream smooth finish.

Replay polimerico lucido  
 gloss polymeric

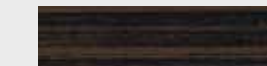

Ebano  
 Ebony  
 A RICHIESTA

Replay polimerico liscio  
 smooth polymeric

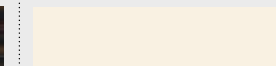

Crema lucido  
 Gloss cream  
 STANDARD

Composizione 14 

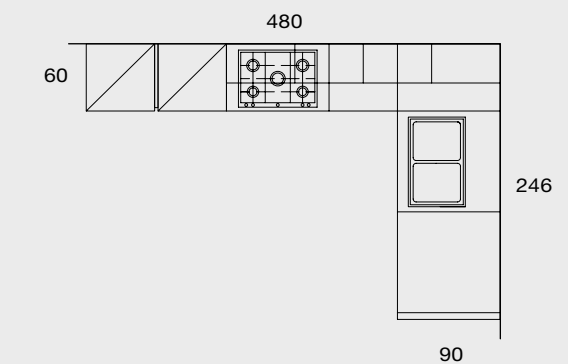



# IL TUO STILE, UN'UNICA SCELTA

YOUR STYLE, THE ONLY CHOICE

## Composizione 15

REPLAY + ALLEGRA. Cucina con gola in finitura bianco opaco. Basi in finitura bianco lucido. Basi ribassate e pensili in finitura bordeaux lucido a richiesta. Pensili in vetro stopsol con telaio alluminio brill. / Kitchen with groove in matt white finish. Base units in gloss white finish. Wall units and living zone in glossy bordeaux Just in time finish. Wall units in stopsol glass.

Replay polimerico lucido gloss polymeric	Replay polimerico liscio smooth polymeric	Brillant vetro colorato coloured glass
		
Bordeaux A RICHIESTA	Bianco lucido Gloss white STANDARD	Stopsol STANDARD

## Composizione 15

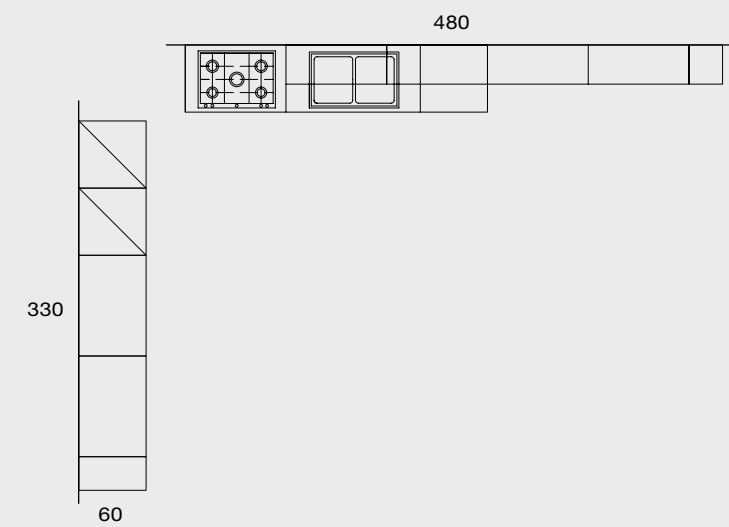

# REPLAY+GLORIA SISTEMA MANIGLIA A "TASCA" - "POCKET" HANDLE SYSTEM

Gloria è un sistema con maniglia a "tasca" incassata in testa all'anta con gola.

La maniglia Up è incassata in testa all'anta e la gola facilita l'apertura.

Gloria is a system with handle "pocket" embedded in the head with the leaf throat.

Up The handle is recessed in the head and throat sash for easy opening.

## Finiture gola piatta Flat groove finishes



Brill

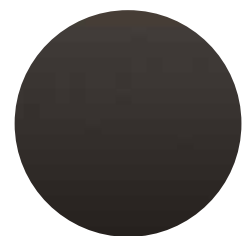

Brown

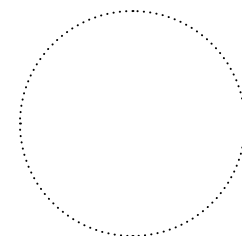

Bianco opaco  
Matt white

## Finiture maniglia UP UP handle finishes



Brill



Brown



Bianco opaco  
Matt white







## DESIGN SENZA TEMPO

PARTICOLARI RICERCATI CONTRIBUISCONO AD ELEVARE AI MASSIMI LIVELLI LA FUNZIONALITÀ DELLA CUCINA: COME LA LIBRERIA A GIORNO IN POLIMERICO LARICE GRIGIO LUCIDO RICAVATA NELLE COLONNE MIDI IN POLIMERICO LUCIDO BIANCO.

### TIMELESS DESIGN

Refined details help raise functionality of the kitchen to the highest levels: like the open bookcase in gloss grey larch polymer obtained in the midi column units in gloss white polymer.



## Composizione 16

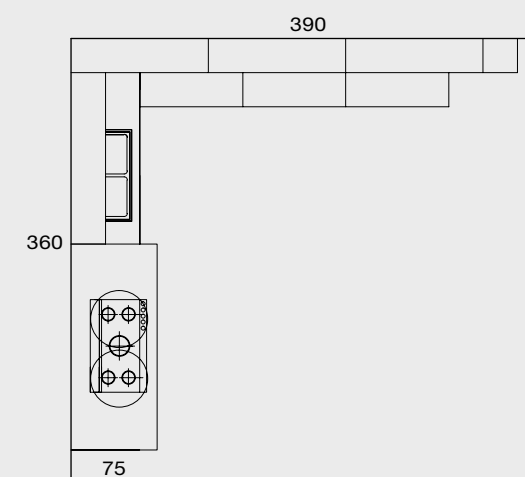

### Composizione 16

**REPLAY + GLORIA.** Cucina con tasca finitura bianco opaco e maniglia ad incasso Up. Basi, colonne midi e mensole in finitura liscio bianco lucido. Basi ribassate, pensili e vani a giorno in finitura larice grigio lucido. / Kitchen with pocket white finish and recessed handle Up. Bases, midi columns and shelves in gloss white finish. Wall units, low bases and open compartments in gloss grey larch.

Replay polimerico lucido  
gloss polymeric



Larice grigio  
Grey larch  
STANDARD

Replay polimerico liscio  
smooth polymeric



Bianco lucido  
Gloss white  
STANDARD





## OGNI COSA AL SUO POSTO

PRATICO E AMPIO PIANO D'APPOGGIO,  
LA PENISOLA CELA ULTERIORI PREZIOSI SPAZI:  
COME IL VANO RICAVATO NELLA BASE  
O IL SISTEMA DI CASSETTI PER RIPORRE  
OGNI TIPO DI UTENSILE.

## EVERYTHING IN ITS PLACE

A practical and ample support top, the peninsula conceals other valuable spaces: like the compartment obtained in the base or the drawer system for holding any kind of utensil.



## Composizione 17

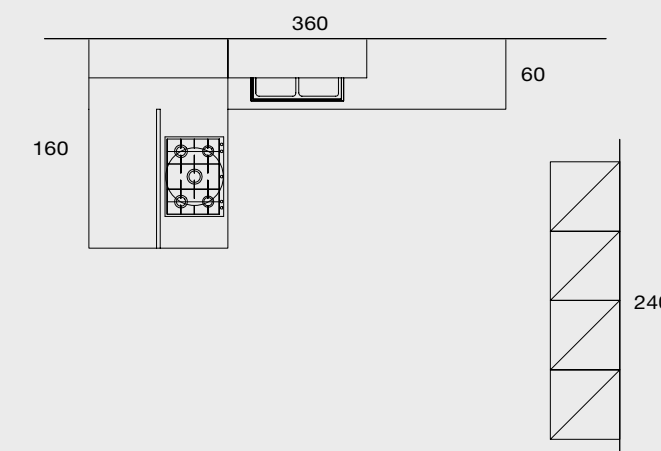

### Composizione 17

**REPLAY + GLORIA.** Cucina con tasca finitura brill e maniglia ad incasso Up. Soluzione a penisola composta da basi in finitura dogato noce opaco e liscio lucido crema. Pensili in vetro stopsol. Colonne in finitura liscio lucido crema e vetro stopsol con telaio in alluminio brill. / Kitchen with pocket brill finish and recessed handle Up. Peninsula solution consisting of base units in matt walnut slatted and gloss cream finish. Wall units in stopsol glass. Column units in gloss cream finish and stopsol glass.

Replay polimerico dogato  
slatted polymeric



Noce opaco  
Matt walnut  
STANDARD

Replay polimerico liscio  
smooth polymeric

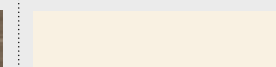

Crema lucido  
Gloss cream  
STANDARD

Brillant vetro colorato  
coloured glass

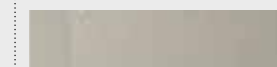

Stopsol  
STANDARD



# SOFISTICATI ABBINAMENTI

SOPHISTICATED COMBINATIONS



**Composizione 18**  
**REPLAY + GLORIA.** Cucina con tasca finitura brill e maniglia ad incasso Up. Basi e colonne in finitura tortora lucido. Pensili e basi ribassate in vetro colorato nero con telaio alluminio brill. / Kitchen with groove in brill finish, and flush-mounting Up handle. Base units and tall units in glossy dove-colour finish. Lowered wall units and base units in coloured black glass with brill aluminium frame.

Replay polimerico liscio  
 smooth polymeric



Tortora lucido  
 Gloss dove-colour  
 STANDARD

Brillant vetro colorato  
 coloured glass



Nero liscio  
 Smooth black  
 OPTIONAL

Composizione 18

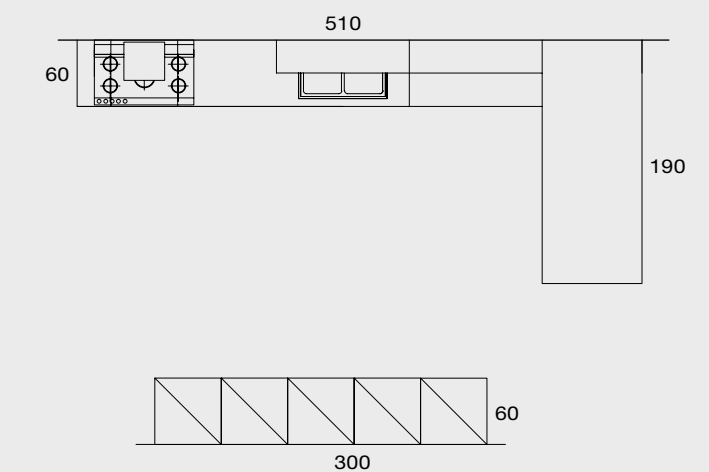



# ESTETICAMENTE PREGIATA

AESTHETICALLY PRECIOUS

## FACILE APERTURA

UNA SCANALATURA VERTICALE O ORIZZONTALE CHE, NELLO SPESSORE DELL'ANTA STESSA, ACCOGLIE IL SISTEMA DI MANIGLIA A GOLA. UN'INCISIONE PRATICA E COMODA CHE FACILITA IL MOVIMENTO DI APERTURA E CHIUSURA.

## EASY OPEN

A groove vertical or horizontal that, in the thickness of the door welcomes the grooved handle. A practical and convenient incision which help the movement of opening and closing.



Composizione 01 page 8

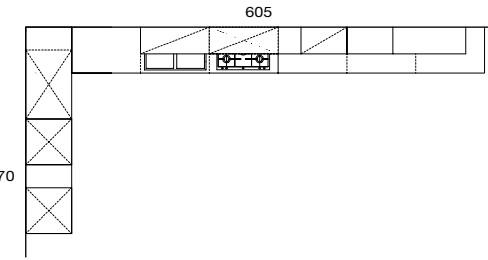

- |   |   |  |
|---|---|--|
| Replay polimerico venato<br>grained polymeric | Replay polimerico opaco<br>matt polymeric | Tetris laccato opaco<br>matt lacquered |
|   |   |  |
| Pino nero<br>Black pine<br>A RICHIESTA        | Onyx<br>A RICHIESTA                       | Bianco<br>White                        |
| Grigio Daitona<br>Daitona grey<br>A RICHIESTA |   |  |

Composizione 02 page 14

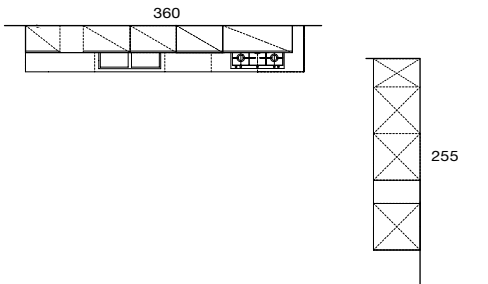

- |   |   |  |
|---|---|--|
| Replay polimerico venato<br>grained polymeric | Replay polimerico opaco<br>matt polymeric | Tetris laccato opaco<br>matt lacquered |
|   |   |  |
| Pino basalto<br>Basalt pine<br>A RICHIESTA    | Onyx<br>A RICHIESTA                       | Grigio Piacenza<br>Piacenza grey       |

Composizione 03 page 16

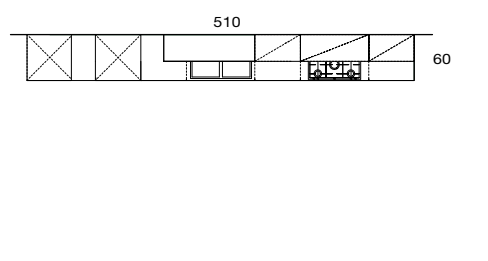

- |  |   |  |
|--|---|--|
| Replay polimerico liscio<br>smooth polymeric | Replay polimerico venato<br>grained polymeric | Tetris laccato opaco<br>matt lacquered |
|  |   |  |
| Bianco opaco<br>Matt white<br>STANDARD       | Pino grigio<br>Grey pine<br>A RICHIESTA       | Acquamarina<br>Aquamarine              |

Composizione 04 page 18

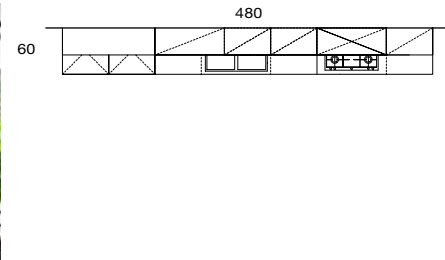

- |  |   |  |
|--|---|--|
| Replay polimerico liscio<br>smooth polymeric | Replay polimerico venato<br>grained polymeric | Tetris laccato opaco<br>matt lacquered |
|  |   |  |
| Bianco opaco<br>Matt white<br>STANDARD       | Pino sabbia<br>Sand pine<br>A RICHIESTA       | Bianco gesso<br>Chalk white            |

Composizione 05 page 24

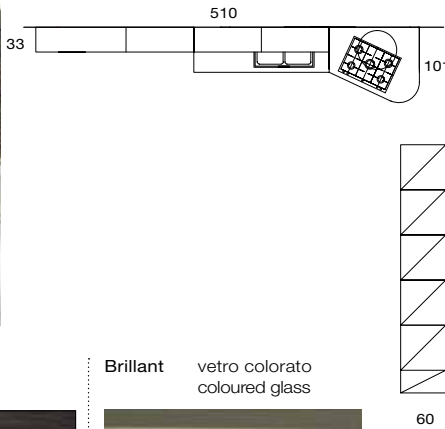

- |   |   |
|---|---|
| Replay polimerico lucido<br>gloss polymeric | Brillant vetro colorato<br>coloured glass |
|   |   |
| Larice bianco<br>White larch<br>STANDARD    | Larice grigio<br>Grey larch<br>STANDARD   |
|   | Stopsol<br>STANDARD                       |

Composizione 06 page 28

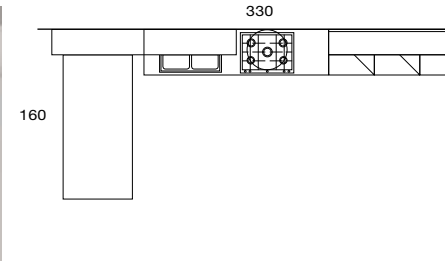

- |  |
|--|
| Replay polimerico liscio<br>smooth polymeric |
|  |
| Bianco opaco<br>Matt white<br>STANDARD       |

Composizione 07 page 32

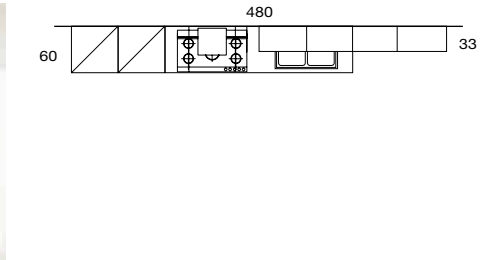

- |   |   |
|---|---|
| Replay polimerico dogato<br>slatted polymeric | Brillant vetro colorato<br>coloured glass       |
|   |   |
| Crema lucido<br>Gloss cream<br>STANDARD       | Rovere scuro opaco<br>Matt dark oak<br>STANDARD |

Composizione 08 page 36

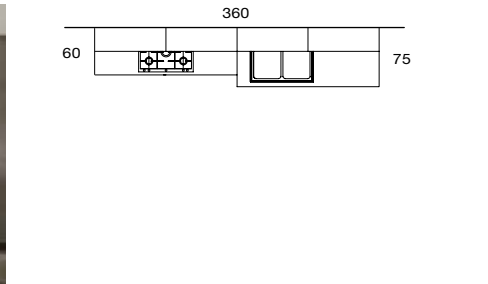

- |   |   |  |
|---|---|--|
| Replay polimerico dogato<br>slatted polymeric | Brillant vetro colorato<br>coloured glass           | Vetro corda dogato<br>Slatted cord glass<br>OPTIONAL |
|   |   |  |
| Noce opaco<br>Matt walnut<br>STANDARD         | Vetro corda liscio<br>Smooth cord glass<br>OPTIONAL | Vetro corda dogato<br>Slatted cord glass<br>OPTIONAL |

Composizione 09 page 40

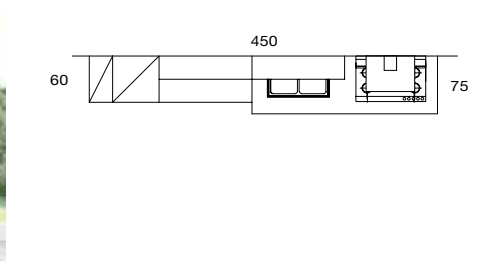

- |   |  |   |
|---|--|---|
| Replay polimerico dogato<br>slatted polymeric | Replay polimerico liscio<br>smooth polymeric | Brillant vetro colorato<br>coloured glass |
|   |  |   |
| Noce opaco<br>Matt walnut<br>STANDARD         | Crema lucido<br>Gloss cream<br>STANDARD      | Stopsol<br>STANDARD                       |

Composizione 10 page 42

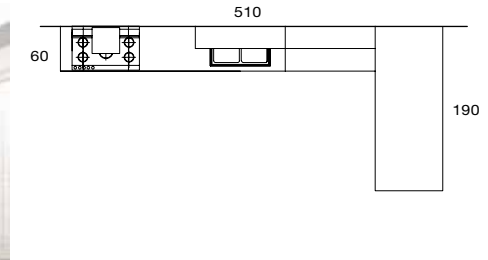

- |  |   |  |
|--|---|--|
| Replay polimerico<br>polymeric                   | Brillant vetro colorato<br>coloured glass | Bianco lucido<br>Gloss white<br>OPTIONAL |
|  |   |  |
| Bordeaux lucido<br>Gloss bordeaux<br>A RICHIESTA | Vetro satinato<br>Satin glass<br>STANDARD | Bianco lucido<br>Gloss white<br>OPTIONAL |

Composizione 11 page 48

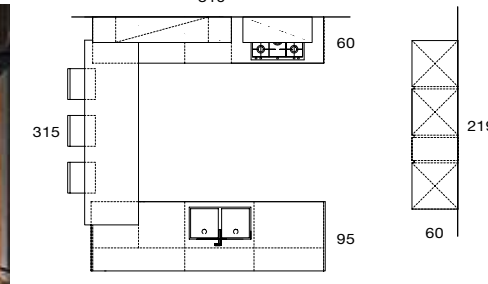

- |  |  |                              |  |
|--|--|------------------------------|--|
| Replay polimerico<br>polymeric         | Replay polim. venato<br>grained polym. | Alevè laminato<br>laminated  | Tetris laccato opaco<br>matt lacquered |
|  |  |                              |  |
| Bianco opaco<br>Matt white<br>STANDARD | Pino nero<br>Black pine<br>A RICHIESTA | Olmo mercurio<br>Mercury elm | Arancio<br>Orange                      |
|  |  |                              | Piombo<br>Lead                         |

Composizione 12 page 54

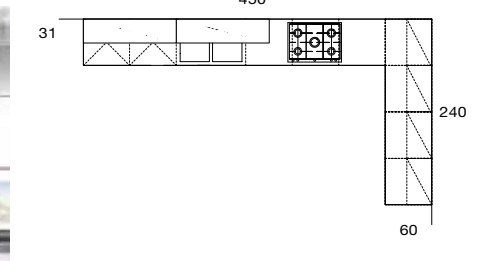

- |  |   |
|--|---|
| Replay polimerico<br>polymeric           | Replay polimerico venato<br>grained polymeric |
|  |   |
| Bianco lucido<br>Gloss white<br>STANDARD | Pino grigio<br>Grey pine<br>A RICHIESTA       |

Composizione 13 page 56

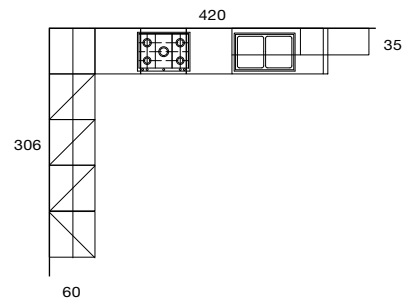

- Replay polimerico lucido  
gloss polymeric
- Larice grigio  
Grey larch  
STANDARD
- Larice bianco  
White larch  
STANDARD

Composizione 14 page 60

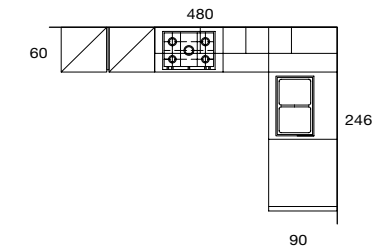

- Replay polimerico lucido  
gloss polymeric
- Replay polimerico liscio  
smooth polymeric
- Ebano I  
Ebony  
A RICHIESTA
- Crema lucido  
Gloss cream  
STANDARD

Composizione 15 page 62

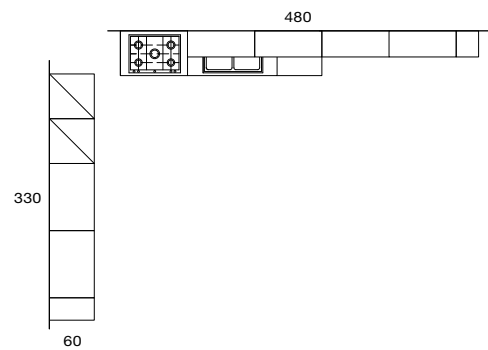

- Replay polimerico lucido  
gloss polymeric
- Replay polimerico liscio  
smooth polymeric
- Brillant vetro colorato  
coloured glass
- Bordeaux  
A RICHIESTA
- Bianco lucido  
Gloss white  
STANDARD
- Stopsol  
STANDARD

Composizione 16 page 66

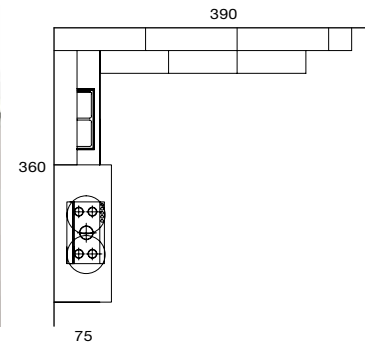

- Replay polimerico lucido  
gloss polymeric
- Replay polimerico liscio  
smooth polymeric
- Larice grigio  
Grey larch  
STANDARD
- Bianco lucido  
Gloss white  
STANDARD

Composizione 17 page 70

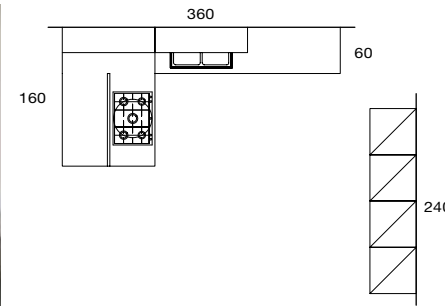

- Replay polimerico dogato  
slatted polymeric
- Replay polimerico liscio  
smooth polymeric
- Brillant vetro colorato  
coloured glass
- Noce opaco  
Matt walnut  
STANDARD
- Crema lucido  
Gloss cream  
STANDARD
- Stopsol  
STANDARD

Composizione 18 page 74

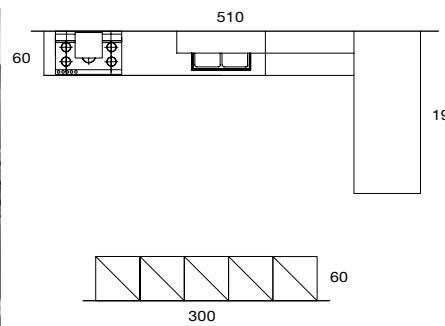

- Replay polimerico liscio  
smooth polymeric
- Brillant vetro colorato  
coloured glass
- Tortora lucido  
Gloss dove-colour  
STANDARD
- Nero liscio  
Smooth black  
OPTIONAL

# Replay

Tipologie di zoccoli  
Types of baseboards



H. 12 cm  
PVC colore inox a specchio  
PVC colour mirror finish steel  
STANDARD



H. 12 cm  
Alluminio colore Brown  
Aluminium colour Brown  
OPTIONAL



H. 10 / 15 cm  
PVC colore inox a specchio  
PVC colour mirror finish steel  
OPTIONAL



H. 12 cm  
PVC colore bianco opaco  
PVC colour matt white  
OPTIONAL



H. 10 / 12 cm  
PVC colore inox  
PVC colour steel  
OPTIONAL

## BRILLANT vetri di serie

Standard glass

Tipologia telaio vetro alluminio  
Types of frame glass aluminium



Finitura brill (di serie)  
Brill finish (standard)



Finitura brown  
Brown finish



Finitura bianco opaco  
Matt white finish

Vetri decor floreali di serie  
Standard floral decor



Bianco  
White

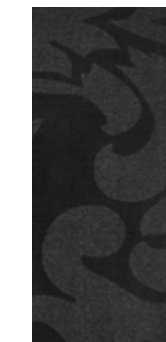

Nero  
Black

Vetri lisci trasparenti di serie  
Standard smooth transparent



Stopsol

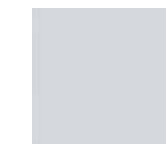

Satinato  
Satin finish

## BRILLANT vetri opzionali

Optional glass

Vetri lisci e dogati colorati opzionali  
Optional coloured glass smooth and slatted



Bianco  
White

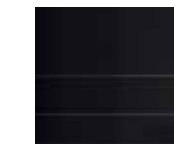

Nero  
Black



Corda  
Cord



Acquamarina  
Aquamarine



Bordeaux



Prugna  
Plum



Petrolio  
Petroleum

Vetri colorati satinati opzionali  
Optional smooth coloured



Bianco opaco  
Matt white



Corda opaco  
Matt cord

Vetri opzionali  
Optional glass



Fumè con pass-partout argento  
Smoke-grey with silver passe-partout

Le finiture e i colori sono indicativi e possono subire variazioni dovute alla tecnica di stampa. Finisings and colours are approximate and they may vary during the printing process.

# Replay

Polimerici lisci **standard**  
Smooth polymeric



Bianco lucido e opaco  
Gloss and matt white

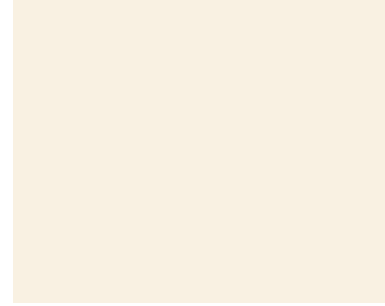

Crema lucido  
Gloss Cream



Tortora lucida  
Gloss dove-colour

Polimerici dogati **standard**  
Slatted polymeric

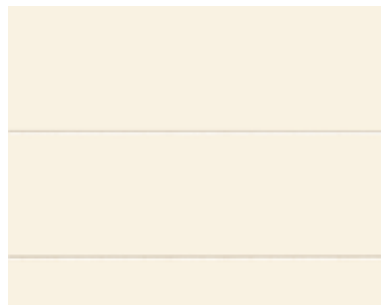

Crema lucido  
Gloss cream



Noce opaco  
Matt walnut



Ciliegio opaco  
Matt cherry



Rovere scuro opaco  
Matt dark oak

Polimerici finitura larice **standard**  
Larch finish polymeric



Larice bianco lucido  
Gloss white larch



Larice grigio lucido  
Gloss grey larch

Polimerici venati materici **A RICHIESTA**  
Textured grained polymeric



Pino bianco  
White pine



Pino sabbia  
Sand pine



Pino grigio  
Grey pine



Pino basalto  
Pine basalt



Pino nero  
Black pine

Polimerici lucidi **A RICHIESTA**  
Glossy polymeric



Lana grey



Sand



Fumo di Londra  
London smoke



Bordeaux



Acciaio  
Steel



Ebano  
Ebony

Polimerici opachi **A RICHIESTA**  
Matt polymeric

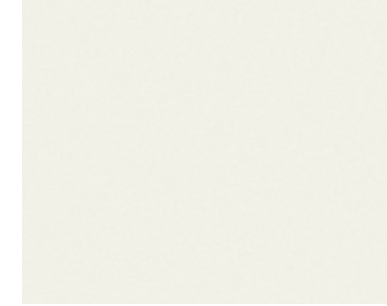

Cloud

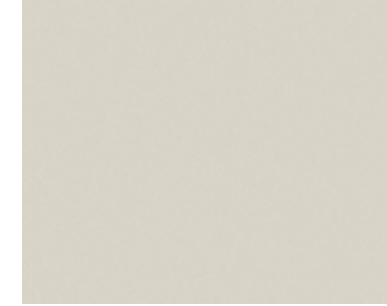

Onyx



Shark



Grigio Dakota  
Dakota grey



Grigio Daitona  
Daitona grey



Monolite



Grigio monzone  
Grey monsoon

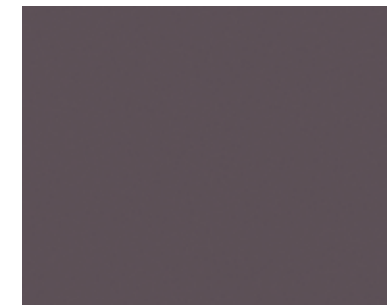

Violaceo  
Purple

# Replay

## Maniglie Handles



Maniglia di serie  
/ Standard handle



DUSE "A"  
M2A Cromo lucido  
Bright chrome



Maniglia opzionale  
/ Optinal handle



DUSE "B"  
M2AB Nichel satinato  
Satin-finish nickel



Maniglia opzionale consigliata  
/ Optional handle recommended



ONDA  
M2C Cromo lucido  
Bright chrome



Maniglia sistema gola gloria.  
/ System gloria handle.



UP  
Brill / Brown / Bianca opaca  
Brill / Brown / Matt white

### MANIGLIE OPZIONALI / OPTIONAL HANDLES



DAITONA  
M2AC Cromo  
Chrome



MB0B  
Cromo lucido  
Bright chrome



MB0C  
Cromo lucido  
Bright chrome



GICONDA  
M2AF Cromo lucido  
Bright chrome



MD0  
Cromo lucido  
Bright chrome



FIOCCO  
M2AQ Cromo lucido  
Bright chrome



CLOSE  
MA0F Cromo lucido  
Bright chrome  
MA0E Titanio  
Titanium



MC0  
Inox spazzolato  
Brushed stainless steel



LINE  
M2AU Cromo  
Chrome



MB0  
Nichel satinato  
Satin-finish nickel



MB0D  
Cromo lucido  
Bright chrome



VALZER  
M2AE Inox satinato  
Satin-finish  
stainless steel



MA0B  
Cromo lucido  
Bright chrome



MA0  
Cromo lucido  
Bright chrome



OPEN  
MA0D Cromo lucido  
Bright chrome



TWIST  
M2AV Cromo lucido  
Bright chrome



WAVE  
M2AZ Cromo lucido  
Bright chrome



PULL  
M2AH Brill  
M2AI Brown  
M2AL Bianco opaco  
Matt white



**G\* GRASS**

IL PROGRAMMA COMPLETO DI CASSETTI  
VERSATILE DAL DESIGN ESCLUSIVO,  
UNICO E FUNZIONALE

THE COMPLETE PROGRAM OF DRAWERS VERSATILE  
DESIGN EXCLUSIVE, UNIQUE AND FUNCTIONAL

Il passaggio a GRASS ha consentito di proporre l'intera gamma di elementi estraibili della STOSA sotto un'unica configurazione di sponde carenate che, oltre a soddisfare il fattore estetico, con le eleganti finiture in acciaio, conferiscono anche al prodotto di base un elevato standard qualitativo, il tutto abbinato ad una estrema coerenza in tutta la linea di prodotti siano essi standard che ridotti, basata sull'estrema scorrevolezza, resistenza e stabilità delle guide.

The change to GRASS permit to the entire range of STOSA pullout elements to be offered in a single configuration of covered sides which, as well as meeting aesthetic requirements, with elegant finishes in steel, give the basic product a high quality standard, all with extreme consistency in the whole line of standard and reduced products, based on the extreme smoothness, rigidity and stability of the runners.



**SPONDE STANDARD**  
Sponde scatolate in acciaio.  
Il sistema completo, preciso e personalizzato.

**STANDARD SIDES**  
Box-type steel sides.  
The complete, careful and custom system.



**GUIDE**  
Sistema di apertura, ad estrazione totale. Standard - Ammortizzate - Push-pull.

**RUNNERS**  
Full-extraction opening system. Standard - Damped - Push-pull.



**SPONDE INOX OPTIONAL**  
Sponde scatolate in acciaio inox dal design elegante, ed eccellenti proprietà di scorrimento.

**OPTIONAL STAINLESS STEEL SIDES**  
Box-type stainless steel sides featuring an elegant design, and excellent sliding.



**ACCESSORI**  
Antisgancio di serie: su tutta la gamma, integrabile a richiesta col sistema di sicurezza apertura per bambini.

**ACCESSORIES**  
Safety device provided standard: for all the range, on request it can be integrated with the child safety opening system.

Design: Adriani e Rossi Edizioni  
A. D. e Grafica: Adriani e Rossi Edizioni  
Foto: Studio Indoor (Oderzo - TV)  
Fotolito: Bieffe Fotolito - Vr  
Stampa: Eurotipo - Vr  
stampato in Italia Settembre 2013



**STOSA**  
CUCINE



## Stosa S.p.A.

**STAB., SEDE AMM.VA E RECAPITO POSTALE:**  
S.S. Cassia, Km. 149,5  
53040 Radicofani (SI) Italy

**GPS:**  
N 42° 53' 50,6"  
E 11° 45' 53,5"

**INFO:**  
tel. +39 0578 5711 r.a.  
fax +39 0578 50088

**INFO LINE:**  
840 000 691

[www.stosa.it](http://www.stosa.it)

[stosa@stosa.it](mailto:stosa@stosa.it)



MPA03181